

ROLAMENTO RADIAL ESFERA RIGIDA COM FLANGE, EM MINIATURA

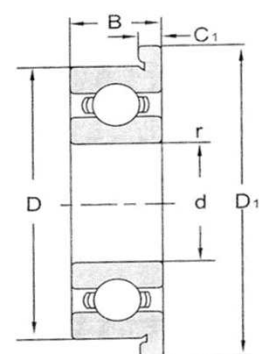

open type

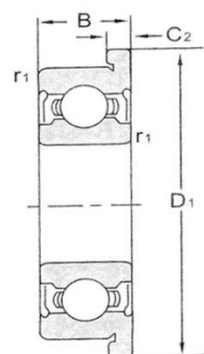

2Z

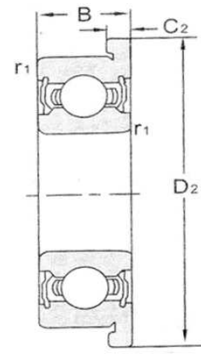

2RS

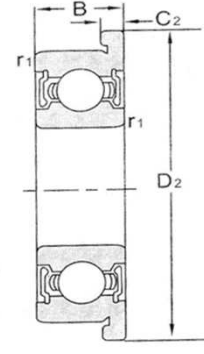

2RZ

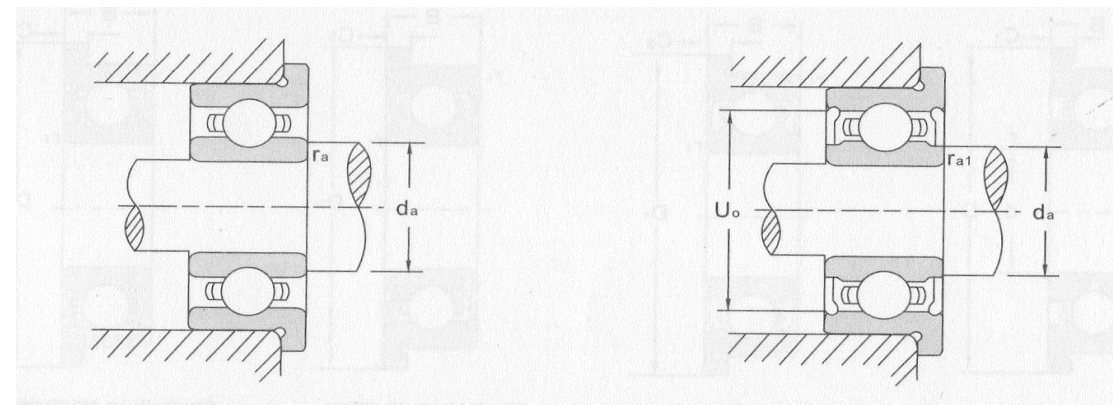

Main Dimensions(mm)							Model				Basic Dynamic Load Ratings C(N)	Basic Static Load Ratings Co(N)	Permissible Rotational Speed(rpm)			Assembly Dimensions(mm)				Reference Weigh (g)				
d	D	D ₁	B	C ₁	r (Min)	D ₂	B ₁	C ₂	r ₁ (Min)	Open type			Shielded type	Contact sealed type	Non-contact sealed type	Grease Lubricatio Open type.2Z. 2RZ	Grease Lubricatio 2RS	Oil lubrication	d _a (Min) Open type	d _a (Min) Sealed type Shielded type	r _a (Max) Open type	r _{a1} (Max) Sealed type Shielded type	Open type	Sealed type Shielded type
1.0	3	3.8	1.00	0.30	0.05	3.80	1.50	0.45	0.05	F681	F681-2Z	-	-	80	23	130000	-	150000	1	-	0.05	-	0.04	-
1.0	4	5.0	1.60	0.50	0.10	5.00	2.30	0.60	0.10	F691	F691-2Z	-	-	140	36	100000	-	120000	2	-	0.10	-	0.14	-
1.2	4	4.8	1.80	0.40	0.10	-	-	-	-	MF41X	-	-	-	138	35	110000	-	130000	2	-	0.10	-	0.12	-
1.5	4	5.0	1.20	0.40	0.05	5.00	2.00	0.60	0.05	F68/1.5	F68/1.5-2Z	-	-	112	33	100000	-	120000	2	2.2	0.05	0.05	0.12	0.17
1.5	5	6.5	2.00	0.60	0.15	6.50	2.60	0.80	0.15	F69/1.5	F69/1.5-2Z	-	-	240	69	85000	-	100000	3	2.5	0.15	0.15	0.26	0.30
1.5	6	7.5	2.50	0.60	0.15	7.50	3.00	0.80	0.15	F60/1.5	F60/1.5-2Z	-	-	330	99	75000	-	90000	3	2.7	0.15	0.15	0.42	0.52
2.0	5	6.1	1.50	0.50	0.08	6.10	2.30	0.60	0.08	F682	F682-2Z	-	-	188	59	85000	-	100000	3	2.8	0.08	0.08	0.19	0.25
2.0	5	6.2	2.00	0.60	0.10	6.20	2.50	0.60	0.10	MF52	MF52-2Z	-	-	188	59	85000	-	100000	3	2.6	0.10	0.10	0.21	0.25
2.0	6	7.5	2.30	0.60	0.15	7.50	3.00	0.80	0.15	F692	F692-2Z	-	-	330	99	75000	-	90000	3	3.2	0.15	0.15	0.35	0.45
2.0	6	7.2	2.50	0.60	0.15	-	-	-	-	MF62	MF62-2Z	-	-	330	99	75000	-	90000	3	-	0.15	-	0.36	-
2.0	7	8.2	2.50	0.60	0.15	8.20	3.00	0.60	0.15	MF72	MF72-2Z	-	-	385	128	63000	-	75000	3	3.2	0.15	0.15	0.49	0.57
2.0	7	8.5	2.80	0.70	0.15	8.50	3.50	0.90	0.15	F602	F602-2Z	-	-	385	128	63000	-	75000	3	3.2	0.15	0.15	0.60	0.73
2.5	6	7.1	1.80	0.50	0.08	7.10	2.60	0.80	0.08	F68/2.5	F68/2.5-2Z	-	-	209	73	72000	-	80000	4	3.7	0.08	0.08	0.25	0.41
2.5	7	8.5	2.50	0.70	0.15	8.50	3.50	0.90	0.15	F69/2.5	F69/2.5-2Z	-	-	385	128	63000	-	75000	4	3.7	0.15	0.15	0.50	0.68
2.5	8	9.2	2.50	0.60	0.20	-	-	-	-	MF82X	-	-	-	560	179	60000	-	67000	4	-	0.20	-	0.68	-
2.5	8	9.5	2.80	0.70	0.15	9.50	4.00	0.90	0.15	F60/2.5	F60/2.5-2Z	-	-	550	175	60000	-	67000	4	3.7	0.15	0.15	0.71	0.95
3.0	6	7.2	2.00	0.60	0.08	7.20	2.50	0.60	0.08	F673	F673-2Z	-	-	209	73	71000	-	80000	4	3.6	0.08	0.08	0.26	0.31
3.0	7	8.1	2.00	0.50	0.10	8.10	3.00	0.80	0.10	F683	F683-2Z	-	-	385	129	62000	-	73000	4	4.2	0.10	0.10	0.38	0.53
3.0	8	9.2	2.50	0.60	0.15	-	-	-	-	MF83	-	-	-	560	179	60000	-	67000	4	-	0.15	-	0.56	-
3.0	8	9.5	3.00	0.70	0.15	9.50	4.00	0.90	0.15	F693	F693-2Z	-	-	560	179	60000	-	67000	4	4.2	0.15	0.15	0.71	0.95
3.0	9	10.0	2.50	0.60	0.20	10.60	4.00	0.80	0.15	MF93	MF93-2Z	-	-	640	226	56000	-	66000	5	4.2	0.20	0.15	0.84	1.10

Main Dimensions(mm)										Model				Basic Dynamic	Basic Static	Permissible Rotational Speed(rpm)			Assembly Dimensions(mm)				Reference Weigh (g)	
d	D	D ₁	B	C ₁	r (Min)	D ₂	B ₁	C ₂	r ₁ (Min)	Open type	Shielded type	Contact sealed type	Non-contact sealed type			Load Ratings C(N)	Load Ratings Co(N)	Grease Lubricatio Open type.2Z. 2RZ	Grease Lubricatio 2RS	Oil lubrication	d _a (Min) Open type	d _a (Min) Sealed type Shielded type	r _a (Max) Open type	r _{a1} (Max) Sealed type Shielded type
3.0	9	11.0	3.00	0.70	0.15	10.50	5.00	1.00	0.15	F603	F603-2Z	-	-	640	226	55000	-	65000	4	4.2	0.15	0.15	0.93	1.30
3.0	10	12.0	4.00	1.00	0.15	11.50	4.00	1.00	0.15	F623	F623-2Z	-	-	615	226	46000	-	55000	4	4.2	0.15	0.15	1.65	1.75
4.0	7	8.2	2.00	0.60	0.08	8.20	2.50	0.60	0.08	F674	F674-2Z	-	-	315	115	60000	-	68000	5	4.6	0.08	0.08	0.30	0.40
4.0	8	9.2	2.00	0.60	0.15	9.20	3.00	0.60	0.10	MF84	MF84-2Z	-	-	395	140	56000	-	67000	5	4.8	0.15	0.10	0.47	0.61
4.0	9	10.0	2.50	0.60	0.10	10.30	4.00	1.00	0.10	F684	F684-2Z	-	-	640	226	50000	-	61000	5	5.2	0.10	0.10	0.74	1.20
4.0	10	11.0	3.00	0.60	0.20	11.60	4.00	0.80	0.15	MF104	MF104-2Z	-	-	650	236	48000	-	55000	6	5.2	0.20	0.15	1.00	1.40
4.0	11	13.0	4.00	1.00	0.15	12.50	4.00	1.00	0.15	F694	F694-2Z	F694-2RS	F694-2RZ	715	283	44000	30000	53000	5	5.2	0.15	0.15	1.80	1.90
4.0	12	14.0	4.00	1.00	0.20	13.50	4.00	1.00	0.20	F604	F604-2Z	F604-2RS	F604-2RZ	970	360	40000	28000	47000	6	5.6	0.20	0.20	3.10	3.30
4.0	13	15.0	5.00	1.00	0.20	15.00	5.00	1.00	0.20	F624	F624-2Z	F624-2RS	F624-2RZ	1300	485	38000	32000	45000	6	5.6	0.20	0.20	4.10	4.10
4.0	16	18.0	5.00	1.00	0.30	18.00	5.00	1.00	0.30	F634	F634-2Z	F634-2RS	F634-2RZ	1730	670	36000	31000	43000	6	7.5	0.30	0.30	5.73	5.57
5.0	8	9.2	2.00	0.60	0.08	9.20	2.50	0.60	0.08	F675	F675-2Z	-	-	278	131	53000	-	63000	6	5.6	0.08	0.08	0.33	0.45
5.0	9	10.0	2.50	0.60	0.15	10.20	3.00	0.60	0.15	MF95	MF95-2Z	-	-	435	168	50000	-	60000	6	6.2	0.15	0.15	0.60	0.65
5.0	10	11.0	3.00	0.60	0.15	11.60	4.00	0.80	0.15	MF105	MF105-2Z	-	-	435	168	49000	-	58000	6	6.2	0.15	0.15	1.00	1.30